

P/N 2100 Installation Instructions

1940-1954 Chevy passenger car 5 speed transmission adapter

1. Remove old 3 speed transmission
2. Remove old cross member or modify it to fit the new transmission. See our p/n 2200.
3. Replace clutch disc with 1983-92 Chevrolet S10 clutch disc. 9 1/8" diameter 1"-14 spline. (Sachs p/n BBD4203, not included)

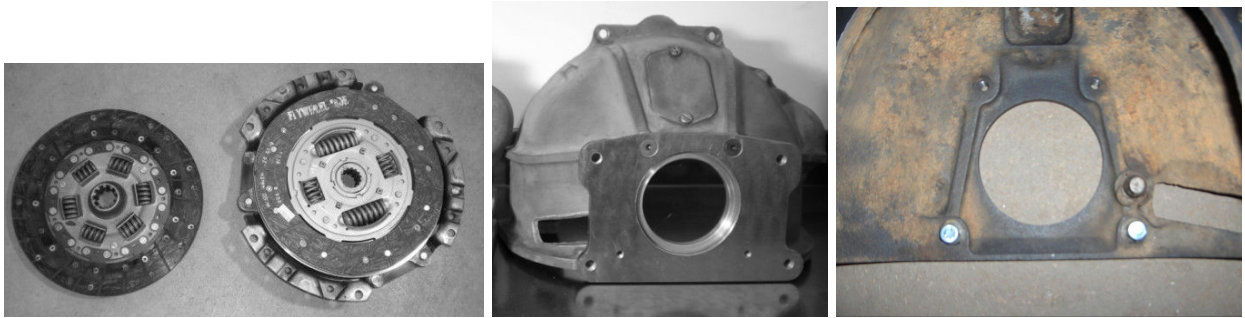

4. Attach trans adapter to the bell housing with (2) 3/8-16 x 1 1/4" flat head hex socket screws in the top holes and (2) 3/8-16 x 1" hex head cap screws and lock washers in the bottom holes. NOTE: The bottom bolts are installed from INSIDE the bell housing and thread into the adapter, as shown in the above photo. The centering ring fits forward into the bell housing.
5. Remove the bearing retainer from the front of the S10 transmission and shorten as shown:

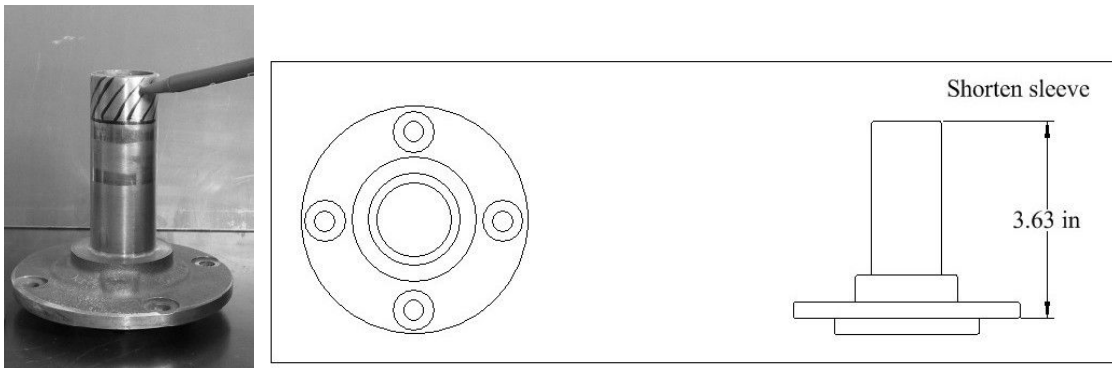

Shorten the sleeve to 3 5/8" from mounting surface.

6. Reinstall the front bearing retainer.
7. Drill out the transmission mounting holes on the transmission to 1/2" diameter.
8. Install the transmission. Install (2) 1/2"-13 x 1 1/4" bolts and lock washers in the top two mounting holes.
9. Install the (2) 1/2" - 13 x 2" studs in the lower two holes. Screw them in until they bottom on the bell housing. Install (2) 1/2 - 13 nuts and lock washers on the lower studs.
10. Be sure all attaching bolts are tight.



Kit Includes:

- Adapter plate
- (2) 3/8-16 x 1 1/4" flat head socket screws
- (2) 3/8-16 x 1" cap screws
- (2) 3/8" lock washers
- (2) 1/2 -13 x 1 1/4" cap screws
- (4) 1/2" lock washers
- (2) 1/2 - 13 x 2" studs
- (2) 1/2 - 13 nuts

Tip: Speedometer cable 75" long- NAPA p/n 615-1605 (not Included)